

## Growth-Effects of Inflation Targeting: The Role of Financial Sector Development

Rangan Gupta\*

*University of Pretoria, Department of Economics  
Pretoria, 0002, South Africa  
E-mail: Rangan.Gupta@up.ac.za*

The paper develops a dynamic general equilibrium monetary endogenous growth model. The closed economy model is inhabited by consumers, firms, a Cournotian monopolistically competitive banking system, besides, an inflation-targeting monetary authority, and, in turn, analyzes the effect of a tight monetary (disinflationary) policy on growth. We show that the effect of a lower inflation target on growth is ambiguous, with the ultimate effect depending on the initial levels of growth and the individual bank size, besides, a whole host of structural parameters defining the preferences and the production structure of the economy.

*Key Words:* Inflation targeting; Economic growth; Financial sector development.

*JEL Classification Numbers:* E31, E44, E52.

### 1. INTRODUCTION

The paper develops a dynamic general equilibrium monetary endogenous growth model of a closed economy characterized, by a monetary authority targeting inflation, and, in turn, analyzes the effect of a tight (disinflationary) monetary policy on growth. Besides, the inflation targeting infinitely-lived government, the model economy is inhabited by consumers, firms and a Cournotian monopolistically competitive banking system. Assuming a monopolistic banking system provides us the flexibility of analyzing the role of financial sector development in determining the growth-effects of lower inflation targets, and, simultaneously, depict a developed and an emerging market economy within the same theoretical framework. Such a

\* I would like to thank an anonymous referee for many helpful comments. All remaining errors are, however, mine.

specification of the banking system is an essential component of our model. As Berthélemy and Varoudakis (1997) points out, countries in which financial sector development has been repressed, as has been the case in most developing nations, usually have highly oligopolistic banking system, however, the banking system is substantially more competitive in the developed countries.

Though there does not exist an universally accepted definition for inflation targeting, in general, the policy involves the public announcement of a quantitative inflation target, the commitment of the monetary authority towards price stability, a high degree of transparency in policy making, and the imposition of the accountability of the central bank. The framework of inflation targeting, has received significant attention from economists and policy makers alike, given that, both developed and developing countries are now targeting inflation.<sup>1</sup>

Recent studies inquiring as to whether tight monetary policy, in such a framework, is growth enhancing, find varied results. While Mishkin (2001), Neumann and von Hagen (2002), Ball and Sheridan (2003), Apergis *et al.*, (2005), Vega and Winkelried (2005), and Mollick *et al.*, (2008) finds positive growth-effect of disinflation, Lavoie (2002), Leon-Ledesma and Thirlwall (2002), Dutt and Ros (2003), Fraga, Goldfajn and Minella (2003), Libanio (2005) and Fang *et al.*, (2009) indicates plausible unfavorable influences of the lower inflation targets on growth. In such a situation, with developing and emerging economies also shifting to such a framework, a pertinent question is what are the essential prerequisites for inflation targeting to have positive growth effects.

In this regard, our analysis, provides a theoretical explanation as to why a disinflationary policy can have ambiguous growth effects and, in the process, identifies the importance of financial sector development as an essential prerequisite to reap the benefits of positive growth effects of inflation targeting. Recently, Mishkin (2004) indicates at four institutional aspects that might be lacking in the emerging market economies for inflation targeting policies to become fruitful. He lists the following (i) weak fiscal and financial institutions; (ii) low credibility of monetary institutions; (iii) currency substitution and liability dollarization; and (iv) greater vulnerability to external shocks, in particular, “sudden stops” of capital inflow. In this paper, we indicate that for lower inflation targets, pursued by a monetary authority, to have positive growth effects, a relatively well-developed financial sector is essential. Our analysis can, thus, be viewed as to providing a theoretical formalization to one of the required essentials,

---

<sup>1</sup>Refer to Neumann and von Hagen (2002), Ball and Sheridan (2003), Fraga, Goldfajn and Minella (2003), Libanio (2005), Vega and Winkelried (2005), Fang *et al.*, (2009, 2010) and Fang and Miller (2010) for details regarding the countries targeting inflation and the starting date of the regime.

stated in Mishkin (2004). The remainder of the paper is organized in the following order: Besides the introduction and conclusion, Section II outlines the economic environment while Section III defines the equilibrium and lays out the balanced growth equations. Finally, Section IV analyzes the effects of a deflationary policy on growth and discusses the results.

## 2. ECONOMIC ENVIRONMENT

We consider an infinitely-lived representative agent model with no uncertainty and complete markets. The economy is populated by four types of decision makers: households, banks, firms, and the government. In this model, there is only one type of consumption good, called the cash goods. The cash good and the investment good, are produced by the same technology. The financial intermediaries are modeled to operate in a Cournotian monopolistically competitive environment and are assumed to hold mandatory reserve requirements. Further, we assume that all capital is intermediated as loans through the banking system.

The resource constraint in the model economy is given by:

$$c_t + i_{kt} \leq Ak_t^\alpha (n_t \bar{k}_t)^{1-\alpha} \quad (1)$$

where  $c_t$  is the consumption of cash goods;  $i_{kt}$  is the investment expenditure in physical capital;  $A$  is a positive scalar;  $0 < \alpha < 1$ , is the elasticity of output with respect to capital;  $n_t$  is the hours of labor supplied inelastically to production (the remaining  $(1 - n_t)$ , is supplied in the banking sector), given the one unit of labor time available, and;  $\bar{k}_t$  denotes the aggregate capital stock. Physical capital evolve according to the following processes:  $k_{t+1} \leq (1 - \delta_k)k_t + i_{kt}$ , where  $k_t$  is the capital stock in period  $t$  and  $\delta_k$  is the depreciation rate. Note the production technology used here is motivated from the works of Romer (1986), Bencivenga and Smith (1991) and Espinosa and Yip (1996). The aggregate capital stock enters the production function to account for a positive externality indicating an increase in labor productivity as the society accumulates capital stock. It must be noted that in equilibrium,  $k_t = \bar{k}_t$ . Since both the consumption and the investment goods, are perfect substitutes on the production side, they both sell for the same nominal price  $p_t$ .

Events in the economy can be captured by the following sequence: At the beginning of each period, a securities market opens. In this market, households receive labor income and proceeds from their savings, made in the previous period, and any lump-sum transfers from the government. Note the only available form of savings for the households is through deposits. Finally, households choose the cash they need to hold for the purchase of cash goods in the next period.

On the production side, given that all capital is intermediated through the banking system, firms must borrow to finance the purchases of capital. The financial intermediaries are assumed to offer one-period deposit contracts to households, and are also required to hold mandatory cash reserves. The freely available deposits remaining after the reserve requirements have been met are then used to make the loans, required to finance the capital needs of the firm. We assume that the banks require resources in the form of labor to carry out their operation. Note the role of money, in this model, is introduced through the cash-in-advance and reserve requirements.

The government makes lump-sum transfer payments to the households and finances the same, in every period, only through seigniorage. For the sake of simplicity we ignore taxes from the government budget constraint, however, for technical reasons outlined below, we assume that there are no government bonds.

### 2.1. Consumers

Before formally stating the consumer's problem, it must be pointed out that the household inelastically supply the available one unit of labor for production and bank operation, the distribution of which is demand determined, based on the firm's and the bank's optimization problems. We assume that there is a large number of identical households that solve the following problem:

$$V = \max_{c_t, d_t, m_{1t}} \sum_{t=0}^{\infty} \beta^t u(c_t) \quad (2)$$

*s.t.* :

$$p_t c_t \leq m_{1t-1} \quad (3)$$

$$d_t + m_{1t} \leq p_t w_t + [1 + R_{dt}]d_{t-1} + (m_{1t-1} - p_t c_t) + T_t \quad (4)$$

with  $d_{t-1}$ ,  $m_{1t-1}$ ,  $R_{dt}$ ,  $w_t$  and  $p_t$  as given. Note,  $\beta$  is the discount factor;  $u = \frac{c_t^{1-\sigma}}{1-\sigma}$  is the instantaneous iso-elastic utility function of the consumer, with  $c_t$  denoting consumption;  $m_{1t-1}$  denotes the cash reserves required in period  $t-1$  to meet the consumption needs of period  $t$ ;  $d_t$  is the bank deposits;  $R_{dt}$  is the nominal interest rate paid on deposits at the end of period  $t$ ;  $T_t$  is the size of the transfer delivered to the household for use in period  $t$ ;  $w_t$  is the real wage rate. Consumers maximize their lifetime utility (equation (2)) subject to equations (3) and (4), to determine a contingency plan for  $\{c_t, d_t, m_{1t}\}_{t=0}^{\infty}$ .

The consumer's optimization problem can be written in the following recursive formulation:

$$J(d_{t-1}, m_{1t-1}) = \max_{c_t, m_{1t}, d_t} \left\{ \begin{array}{l} u(c_t) + \beta J(d_t, m_{1t}) \\ + \lambda_{1t} \left( \begin{array}{l} m_{1t-1} - p_t c_t + p_t w_t \\ + [1 + R_{dt}] d_{t-1} + T_t - d_t - m_{1t} \end{array} \right) \\ + \lambda_{2t} (m_{1t-1} - p_t c_t) \end{array} \right\} \quad (5)$$

The upshot of the dynamic programming problem are the following first order conditions:

$$c_t : u_c(c_t) - p_t(\lambda_{1t} + \lambda_{2t}) = 0 \quad (6)$$

$$d_t : \beta J_1(d_t, m_{1t}) - \lambda_{1t} = 0 \quad (7)$$

$$m_{1t} : \beta J_2(d_t, m_{1t}) - \lambda_{1t} = 0 \quad (8)$$

$$\lambda_{1t} : \left\{ \begin{array}{l} m_{1t-1} - p_t c_t + p_t w_t \\ + [1 + R_{dt}] d_{t-1} + T_t - d_t - m_{1t} \end{array} \right\} = 0 \quad (9)$$

$$\lambda_{2t} : (m_{1t-1} - p_t c_t) = 0 \quad (10)$$

Along with the following envelope conditions:

$$J_1(d_{t-1}, m_{1t-1}) = \lambda_{1t} [1 + R_{dt}] \quad (11)$$

$$J_2(d_{t-1}, m_{1t-1}) = \lambda_{1t} + \lambda_{2t} \quad (12)$$

$$(13)$$

In addition, a transversality condition is necessary to ensure the existence of the households's present-value budget constraint. The household's terminal constraint is interpreted as a non-ponzi condition in which the household cannot borrow against future deposits at a rate greater than that can be repaid. Formally, the transversality condition is represented as:

$$\lim_{T \rightarrow \infty} \left[ \frac{d_T}{\prod_{s=0}^{T-1} [1 + R_{ds}]} \right] \quad (14)$$

Using the first order conditions, along with the envelope conditions, the consumer's problem yields the following efficiency condition.

$$u_c(c_t) = \beta \frac{u_c(c_{t+1})}{p_t} [1 + R_{dt}] \quad (15)$$

Equation (15) is the efficiency condition for consumption. On the left hand side is the marginal cost of foregoing one unit of consumption, while the right hand side of equation (15), is the benefit received in the future from foregone consumption. Note once the consumption path is determined the time paths for the money demand and the deposit can be derived from the constraints, specifically equations (2) and (3) respectively. Using the specific form of the utility function, equation (15) boils down to

$$\left(\frac{c_{t+1}}{c_t}\right)^\sigma = \beta \frac{[1 + R_{dt}]}{\frac{p_{t+1}}{p_t}} \quad (16)$$

## 2.2. Financial intermediaries

The financial sector is modeled along the lines of Berthélemy and Varoudakis (1997). There exists  $N$  banks operating in a Cournotian monopolistically competitive environment. Banks are confronted with a savings (deposit) supply function and they maximize profit at a given point of time, assuming that the volume of savings collected by the  $(N - 1)$  other banks remains unchanged. Note that, though the banks have no way of influencing the interest rate on the loans, since it is tied to the marginal product of the capital,<sup>2</sup> each bank will be able to influence the rate of return on the deposits, given the supply function of savings. We will assume that the behavior of the banks remain unchanged in future periods.

The financial intermediation technology, can be described as follows: With  $\gamma_t$  defined as the fraction of the deposits held as cash reserves by any bank  $i$ , the maximum amount of deposits that can be intermediated by each bank  $i$  is  $(1 - \gamma_t)d_{it}$ . However, we will assume that not all of the available deposits can be loaned out. Each bank can only intermediate  $\psi_{it}(1 - \gamma_t)$  of the savings it collects, given the financial intermediation margin.  $\psi_{it}$  depends on the quantity of real resources used by the bank. Denoting the level of employment in the representative bank by  $\vartheta_{it}$ , we assume that  $\psi_{it} = \psi_i(\vartheta_{it})$ , with  $\psi'_i > 0$ . Given that the banks are symmetrical,  $\vartheta_{it} = \frac{1 - n_t}{N}$ , in equilibrium. The feasibility condition requires that  $l_{it} + m_{2it} \leq d_{it}$ , where  $l_{it}$  is the nominal quantity of bank loans, and;  $m_{2it} \geq \gamma_t d_{it}$ , denotes the cash reserve requirement of bank  $i$ . The conditions should hold as equality as money is return dominated, and, hence, is not optimal for the banks to hold excess reserves.

Given that  $l_{it} = \psi_{it}(1 - \gamma_t)d_{it}$ , there exists increasing returns to scale with respect to deposits  $d_i$  and employment  $\vartheta_i$  at the level of individual banks. As Berthélemy and Varoudakis (1997) indicates, such a technology could be justified on the grounds of learning-by-doing effects in financial intermediation activities, affecting the labor productivity in the banking sector.

<sup>2</sup>Refer to the firm's problem below, for further details.

In accordance with the framework of imperfect competition, these effects are assumed to be internal to the banks. Such learning-by-doing effects could presumably be linked to the size of the financial market (volume of deposits) divided by  $N$ , i.e., to the scale of operation of each bank. The externality, exerted from the real to the financial sector, establishes an interaction between the two sectors of the economy.

The bank's profit maximization problem, formally, can be stated as follows:

$$\max_{d_i, \vartheta_i} \Pi_{Bi} = (1 + R_{lt})l_{it} + m_{2it} - \vartheta_{it}p_t w_t - (1 + R_{dt})d_{it} \quad (17)$$

$$s.t. : l_{it} = \psi_i(1 - \gamma_t)d_{it} \quad (18)$$

$$m_{2it} = \gamma_t d_{it} \quad (19)$$

where  $\Pi_{Bi}$  is the profit function of bank  $i$  and  $R_{lt}$  is the nominal rate of interest on loans.

Profit maximization, realizing,  $\frac{dd_i}{(1+R_{dt})} \times \frac{(1+R_{dt})}{d_t} = \frac{1}{\sigma}$ ,  $d_{it} = \frac{d_t}{N}$ ,  $l_{it} = \frac{l_t}{N}$ , and  $\psi_{it} = \psi\left(\frac{1-n_t}{N}\right)$  yields the following set of first-order conditions:

$$d_{it} : (1 - \gamma_t)\psi(1 + R_{lt}) + \gamma_t = \left(1 + \frac{\sigma}{N}\right)(1 + R_{dt}) \quad (20)$$

$$\vartheta_i : (1 - \gamma_t)(1 + R_{lt})\psi' \frac{d_t}{p_t N} = w_t \quad (21)$$

Note, from equation (20), the difference between the nominal gross rate of return on loans ( $1 + R_{lt}$ ) and the nominal gross rate of deposits ( $1 + R_{dt}$ ) is, as expected, related negatively to the degree of competition in the financial sector, expressed by the size of  $N$ , and positively to the reserve requirements and the reciprocal of the interest elasticity of deposits.

Equation (21) implies the equalization of the marginal product of labor to real wage, in the banking sector. This result indicates the external effect of the real sector on the financial sector through the determination of the flow of loans. The larger the size of the financial market, i.e., higher the size of household savings and, hence, loans, given  $\psi$ , the higher is the labor productivity.

In addition to equation (20) and (21), the free entry condition implying  $\Pi_{Bi} = 0$  for all  $i$ , determines the number of banks in the long-run equilibrium. Setting  $\Pi_{Bi}=0$ , and incorporating the feasibility condition, we have the following condition:

$$(1 - \gamma_t)(1 + R_{lt})\psi_{it}d_{it} + \gamma_t d_{it} - \vartheta_{it}p_t w_t - (1 + R_{dt})d_{it} = 0 \quad (22)$$

Using equation (21) and  $\vartheta_i = \frac{1-n}{N}$ , we can re-write equation (22) as follows:

$$(1 + R_{lt})(1 - \gamma_t)\psi_t[1 - \epsilon_t] + \gamma_t = (1 + R_{dt}) \quad (23)$$

where  $\epsilon (= \frac{1-n}{N} \frac{\psi'}{\psi})$  is the elasticity of the intermediation of deposits with respect to employment at the bank level. Finally, from equations (20) and (23), we have

$$\frac{\sigma}{N} = \frac{(1 + R_{lt})(1 - \gamma_t)\psi_t\epsilon_t}{(1 + R_{lt})(1 - \gamma_t)\psi_t(1 - \epsilon_t) + \gamma_t} \quad (24)$$

Equation (24) determines  $N$  in relation to the size of the financial sector ( $1 - n$ ). It must be pointed out that a positive bi-directional causality is often observed, in cross-sectional data, between the level of financial sector development and intensity of competition in the banking sector.<sup>3</sup> As a result, to ensure that (24) holds, it is assumed that  $\epsilon$  is decreasing with respect to  $\frac{1-n}{N}$ . Note as  $N$  increases the left-hand side falls. Moreover,  $\psi$  falls as well. But given that  $1 - n$  increases with  $N$ ,  $\psi$  starts to increase and marginal product of capital, and, hence,  $(1 + R_{lt})$  starts to fall<sup>4</sup>. Therefore, as a sufficient condition we must assume that  $\epsilon$  is a decreasing function of  $\frac{1-n}{N}$  to maintain the equality in equation (24), given that  $\frac{\sigma}{N}$  has gone down, which can only happen with  $(1 - n)$  increasing more than  $N$ . Realistically, such an assumption is not farfetched since one would expect the percentage change in the coefficient indicating the intermediation of savings expressed as a percentage of the size of the individual bank to show diminishing returns with respect to the latter.

### 2.3. Firms

Firms purchase capital using financing from the bank, besides, using  $n_t$  fraction of the labor time available, to produce the output. The dynamic problem of the firm can be formally represented as follows:

$$\max_{n_t, k_t} \Pi_{Ft} = \sum_{t=0}^{\infty} \rho_t \left[ p_t A k_t^\alpha n_t \bar{k}_t^{1-\alpha} - p_t w_t n_t - (1 + R_{lt-1})l_{t-1} + l_t - p_t i_{kt} \right] \quad (25)$$

*s.t.* :

$$p_{t-1} k_t \leq l_{t-1} \quad (26)$$

$$k_{t+1} \leq (1 - \delta_k) + i_{kt} \quad (27)$$

where  $\rho_t$  is the subjective discount factor of the firms. It must be noted that, from the point of view of the firm, the constraint defined by equation

<sup>3</sup>See Berthélemy and Varoudakis (1997) and the references cited therein for further details.

<sup>4</sup>See Section 2.3 for details.



(25) implies that the firm may well be considered as renting the capital from the bank itself. Because of this scenario, and given the fact that the loans are one period contract, as Chari *et al.* (1995) points out, the firm can be seen as facing a static problem. Hence, the choice of  $\rho_t$  is irrelevant as an implication of the equilibrium condition in such a framework.

Realizing that in equilibrium  $k_t = \bar{k}_t$ , the up-shot of the above static problem of the firm yields the following efficiency conditions:

$$k_t : A\alpha n_t^{1-\alpha} + (1 - \delta_k) = \left( \frac{(1 + R_{Lt})}{\frac{p_t}{p_{t-1}}} \right) \quad (28)$$

$$n_t : A(1 - \alpha)k_t n_t^{-\alpha} = w_t \quad (29)$$

As given by equation (28), the production firm sets the marginal product of capital equal to the real rate of rental. And equation (29) simply states that the firm hires labor up to the point where the marginal product of labor equates the real wage.

#### 2.4. Government

The government commits to a sequence  $\{T_t\}_{t=0}^{\infty}$  of transfers, which, in turn, are financed by seigniorage. The government's budget constraint, in nominal terms, is given by:

$$T_t = m_t - m_{t-1} \quad (30)$$

where  $m_t = m_{1t} + N \times m_{2it}$ . The monetary authority targets the inflation rate. Namely, we assume that  $\pi_t = \pi$ , for all  $t$ . Note that, with  $A\alpha n_t^{1-\alpha} + (1 - \delta_k) = \left( \frac{(1 + R_{Lt})}{\frac{p_t}{p_{t-1}}} \right)$ , and  $n_t = n$ , in steady-state, targeting inflation also implies, targeting the nominal interest rate on loans. Given this policy rule for the rate of inflation, the nominal quantity of money adjusts endogenously to satisfy the demand for money.

As discussed above, notable exceptions from the government budget constraint are taxes and government bonds. Though taxes have been ignored for simplicity, bonds are not included for the following technical reason: In a world of no uncertainty, incorporating government bonds in either the consumer or the bank problem would imply plausible multiplicity of optimal allocations of deposits or loans and government bonds. Since the arbitrage condition would imply a relative price of one between deposits or loans and government debt. One way to incorporate government bonds is to have the financial intermediaries hold government bonds as part of obligatory reserve requirements. Or alternatively, assume that there exists a fixed ratio of government bonds to money. The conclusions of our analysis remains unchanged following such alternative specifications.

### 3. EQUILIBRIUM AND BALANCED-GROWTH EQUATIONS

An equilibrium in this model economy is a sequence of prices  $\{p_t, w_t, R_{Lt}, R_{dt}\}_{t=0}^{\infty}$ , real allocations  $\{c_t, n_t([1 - n_t]), k_t, i_{kt}\}_{t=0}^{\infty}$ , stocks of financial assets  $\{m_t, d_t, l_t\}_{t=0}^{\infty}$ , and policy variables  $\{T_t, \gamma_t, \pi_t = \frac{p_t}{p_{t-1}}\}_{t=0}^{\infty}$  such that:

1. The allocations and stocks of financial assets solves the household's date- $t$  maximization problem, (2), given prices and policy variables.
2. The stock of financial assets solves the bank's date- $t$  profit maximization problem, (17), given prices and policy variables.
3. The real allocations solves the firm's date- $t$  profit maximization problem, (25), given prices and policy variables.
4. The money market equilibrium condition:  $m_t = p_{t+1}c_{t+1} + \gamma_t d_t$  is satisfied for all  $t \geq 0$ .
5. The loanable funds market equilibrium condition:  $p_t k_{t+1} = l_t$  where the total supply of loans  $l_t = \psi(1 - \gamma_t)d_t$  is satisfied for all  $t \geq 0$ .
6. The labor market equilibrium condition:  $n_t^d + (1 - n_t)^d = 1$  for all  $t \geq 0$ .
7. The goods market equilibrium condition require: (1),  $c_t + i_{kt} = Ak_t^\alpha n_t \bar{k}_t^{1-\alpha}$  is satisfied for all  $t \geq 0$ .
8. The government budget is balanced on a period-by-period basis.

To study the long-run behavior of the model, we use the solutions of the maximization problems of the consumer, the financial intermediary and the firm, together with the equilibrium conditions, to calculate the balanced growth equations. Along a balanced growth path, output grows at a constant rate. In general, for the economy to follow such a path, both the preference and the production functions must take on special forms. On the preference side, the consumer, when faced with a stationary path of interest rates must generate a demand for constant growth in consumption. The requirement is satisfied by the, above discussed, iso-elastic utility function, while, on the production side, a sufficient condition is that output is produced by a Cobb-Douglas type production function.

For the sake of tractability, we assume that the government has time invariant policy rules, which means the reserve-ratio,  $\gamma_t$ , besides, the rate of inflation  $\pi_t = \pi_{t+1} = \hat{\pi}$  for all  $t$ , are constant over time. Given this, the economy is characterized by the following system of balanced growth equa-

tions:

$$g^\sigma \hat{\pi} = \beta[1 + R_d] \quad (31)$$

$$\frac{\hat{m}_1}{k} = \hat{\pi} \frac{c}{k} \quad (32)$$

$$(1 - \gamma)\psi(1 + R_L) + \gamma = \left(1 + \frac{\sigma}{N}\right)(1 + R_d) \quad (33)$$

$$\{(1 - \gamma)\psi'(1 + R_L)\} \frac{\hat{d}}{N} = \frac{w}{k} \quad (34)$$

$$\{(1 - \gamma)\psi(1 + R_L) + \gamma - (1 + R_d)\} \frac{\hat{d}}{N} = \left(\frac{1 - n}{N}\right) \frac{w}{k} \quad (35)$$

$$\frac{\hat{m}_2}{k} = \gamma \frac{\hat{d}}{k} \quad (36)$$

$$\frac{1 + R_L}{\hat{\pi}} = A\alpha n^{(1-\alpha)} + (1 - \delta_k) \quad (37)$$

$$\frac{w}{k} = A(1 - \alpha)n^{-\alpha} \quad (38)$$

$$g = \frac{\hat{l}}{k} \quad (39)$$

$$g - 1 + \delta_k = \frac{i_k}{k} \quad (40)$$

$$\frac{\hat{l}}{k} = (1 - \gamma)\psi \frac{\hat{d}}{k} \quad (41)$$

$$\frac{c}{k} + \frac{i_k}{k} = An^{1-\alpha} \quad (42)$$

where  $g = \frac{c_{t+1}}{c_t} = \frac{i_{k_{t+1}}}{i_{k_t}} = \frac{k_{t+1}}{k_t} = \frac{\hat{d}_{t+1}}{\hat{d}_t} = \frac{\hat{L}_{t+1}}{\hat{L}_t} = \frac{\hat{m}_{1t+1}}{\hat{m}_{1t}} = \frac{\hat{m}_{2t+1}}{\hat{m}_{2t}} = \frac{w_{t+1}}{w_t}$  is the balanced gross growth rate of the economy;  $\frac{c}{k}$  and  $\frac{i_k}{k}$ , are the long-run ratios of the respective parts of output relative to the size of the capital stock;  $\hat{d}$  ( $= \frac{d}{p}$ ) is size of real deposit;  $\hat{L}$  ( $= \frac{L}{p}$ ) is size of real loans;  $\hat{m}_i$ ,  $i=1, 2$ , is the real money holdings by the households and banks to meet the cash-in-advance and the cash reserve requirements, respectively, and;  $n$  ( $1 - n$ ) is the balanced growth level of labor supply in the firm and the banking sector. This a non-linear system of twelve equations in twelve variables,  $g$ ,  $R_d$ ,  $R_L$ ,  $\frac{c}{k}$ ,  $\frac{i_k}{k}$ ,  $\frac{\hat{d}}{k}$ ,  $\frac{\hat{l}}{k}$ ,  $\frac{\hat{m}_1}{k}$ ,  $\frac{\hat{m}_2}{k}$ ,  $w$ ,  $n$  and  $N$ , and can be solved given the values of the policy variables  $\pi$ , and  $\gamma$ , to trace the long-run reaction of the system to a change in policy.

#### 4. EFFECTS OF A DISINFLATIONARY POLICY ON GROWTH

We are now ready to analyze the effects of a disinflationary policy (a fall in  $\hat{\pi}$ ) on the rate of growth. Using equations (31), (34), (35), (37), (38), (39) and (41), and realizing that  $\epsilon (= \frac{1-n}{N} \frac{\psi'}{\psi})$ , we obtain two equations of the gross growth rate ( $g$ ) as a function of the size of the individual banks ( $\frac{1-n}{N}$ ). But once the rate of growth and the size of the individual bank is determined we can obtain,  $R_l$ ,  $R_d$ ,  $w$ ,  $\frac{d}{k}$  and  $\frac{l}{k}$  from the above mentioned seven equations, and the rest of the endogenous variables,  $\frac{i_k}{k}$ ,  $\frac{c}{k}$ ,  $\frac{m_1}{k}$ ,  $\frac{m_2}{k}$  and  $N$  from the equations (40), (42), (32), (33) and (41), respectively. The non-linearity of the model, does not allow us to obtain reduced forms equations for the endogenous variables, but we can still analyze the effects of a disinflationary policy graphically. Since our primary interest is the growth rate, we investigate the following two equations, obtained in the way discussed above:

$$g^\sigma = \beta[(1-\gamma)\psi(1-\epsilon)A\alpha n^{1-\alpha} + \frac{\gamma}{\hat{\pi}}] \quad (43)$$

$$g = \frac{A(1-\alpha)n^{-\alpha}(1-n)}{(A\alpha n^{1-\alpha}) + (1-\delta_k)} \frac{1}{\hat{\pi}\epsilon} \quad (44)$$

On one hand, the development of the banking sector lowers the intermediation cost of capital through an increases in  $\psi$  and  $N$ , or alternatively through the size and competition effects. This results in a rise in the return of savings, and, hence, tends to increase the gross rate of economic growth. On the other hand, a reduction in  $n$ , or alternatively, the development of the financial sector lowers the marginal productivity of capital, and therefore, the nominal interest rate paid to the depositors. This effect will negatively influence the rate of growth. Understandably, the positive direct effect will, in general, dominate the negative effect, but the latter, will tend to reduce the impact of the former at higher levels of financial development, resulting in financial development to impact growth positively, but at a diminishing rate. Equation (43) can, thus, be represented by a concave curve in Figure 1. When  $n=1$ , we obtain the steady-state gross growth rate in the absence of any financial intermediation, which in all likelihood is negative.

Now consider equation (44), expressing the accumulation of capital. A reduction in the size of the financial sector, or an increase in  $n$ , leads to a fall in  $\psi$  and a rise in  $\epsilon$  causing the gross rate of growth to fall with  $n$ . The capital accumulation equation is, thus, represented by a negatively-sloped curve, which approaches the vertical axis asymptotically, as represented in Figure 1.

Figure 1 illustrates the possibility of two interior solutions, given by points A and B, in addition to a steady-state corresponding to point C, where there is no financial intermediation activity. We have a steady-state at point C because, in the absence of labor in the financial sector, i.e.,  $n=1$ , there is no reason for the equalization of the wage rate across the real and the banking sectors. The capital accumulation curve is, therefore, extended by the vertical segment  $n=1$ . The equilibrium corresponding to A is the stable one. Note that to the left (right) of point A, the real sector employs relatively small (large) part of the labor force, since the marginal productivity of labor in this region is high (low)<sup>5</sup>. This implies that the wage rate is higher (lower) in the real sector relative to the financial sector and the workforce shifts over to (away from) the real sector.

Note, we are assuming that the  $G_1$  and  $G_2$  curves are such that they produce these three equilibria. Technically, however, it is possible for the  $G_1$  curve to be low enough to be tangential to the  $G_2$  curve at a positive level of  $\frac{1-n}{N}$ , and, hence, implying two equilibria with one being the unstable equilibrium and the other one being the poverty trap. In addition, we can also have a situation, where the  $G_1$  curve is so low that we just have the poverty trap. The following necessary and sufficient conditions are thus required to ensure that we have three equilibria:  $(\beta[(1-\gamma)\psi(1-\epsilon)A\alpha n^{1-\alpha} + \frac{\gamma}{\pi}])^{\frac{1}{\sigma}} > \frac{A(1-\alpha)n^{-\alpha}(1-n)}{(A\alpha n^{1-\alpha}) + (1-\delta_k)} \frac{1}{\pi\epsilon}$  at a positive level of  $(\frac{1-n}{N}) = \Omega$  such that  $\Omega_1 < \Omega < \Omega_2$ , where at  $\Omega_1$  ( $\Omega_2$ ) the slope of the  $G_1$  curve is greater (less) than the slope of the  $G_2$  curve. In other words, we need to assume that the structural parameters of the model are such that for any value of  $\frac{1-n}{N}$  between A and B, the gross growth rate obtained from equation (43), depicting the direct effect of financial development on growth is likely to be higher than the gross growth rate derived from equation (44), capturing the capital accumulation path. Intuitively, this is likely to be the case since the positive effects on growth following an increase in the financial sector development, and, hence, an improvement in the efficiency of allocating capital via equations (43) and (44) should be strong enough to outweigh the sole negative influence on growth due to the lowering of the marginal productivity of capital.

Clearly, the resulting multiple equilibria and the fact that the high-growth equilibrium (A) and the low-growth equilibrium (C) are both stable have significant implications with regard to the take-off possibility of the economy. If the economy is to reach the high-growth long-run equilibrium, the size of the financial sector has to exceed a threshold level that corresponds to the unstable equilibrium B. Therefore, with initially weak financial sector development, economic growth will be halted, the financial sector will tend to shrink and, in turn, cause the economy to converge to

<sup>5</sup>Note that the marginal product of labor is infinite when  $n = 0'$ .

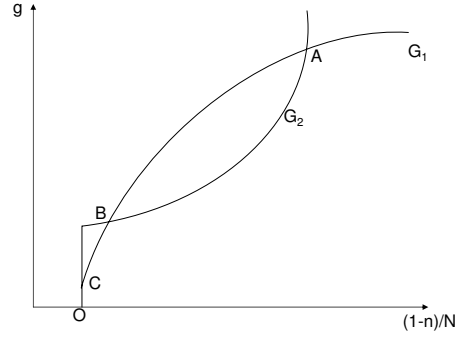
**FIG. 1.** Multiple equilibria

C. Our model, thus, indicates that, once the critical level of financial development has been achieved, the high-growth and high-welfare<sup>6</sup> (stable) equilibrium will be the only available equilibrium for the economic agents to choose.

Note in Figure 1, we present the curves depicted by equations (43) and (44) as  $G_1$  and  $G_2$ , respectively. The disinflationary policy (a reduction in  $\hat{\pi}$ ) will shift the  $G_1$  curve upwards, while, the  $G_2$  curve swing upwards. The shift of the  $G_1$  curve and the swing of the  $G_2$  curve is determined by the following two equations:

$$\frac{dg}{d\hat{\pi}} = -\frac{1}{\sigma g^{(\sigma-1)}} \beta \frac{\gamma}{\hat{\pi}^2} \quad (45)$$

$$\frac{dg}{d\hat{\pi}} = -\frac{A(1-\alpha)n^{-\alpha}(1-n)}{(A\alpha n^{(1-\alpha)} + (1-\delta_k))} \frac{1}{\hat{\pi}^2 \epsilon} \quad (46)$$

<sup>6</sup>The discounted stream of welfare of the economy is captured by  $\frac{U_0}{1-\beta g^{(1-\sigma)}}$ , where  $U_0 = \frac{c_0^{1-\sigma}}{1-\sigma}$ , with  $U_0$  and  $c_0$  representing the initial level of consumption and utility, given the initial level of capital stock. Clearly, with  $\beta g^{(1-\sigma)} < 1$ , the usual condition required for the existence of the life-time utility function, the welfare level of the economy is positively related with  $g$ .

As can be observed from equation (45), the size of the shift of the  $G_1$  curve diminishes (increases) as  $g$  increases if  $\sigma > (<) 1$ , given the initial reduction in  $\hat{\pi}$ . On the other hand, given equation (46), with financial sector development, i.e., an increase in  $(1-n)$ , the magnitude of the swing in the  $G_2$  curve increases. The movements in the two curves are represented in Figures 2 and 3. Hence, the effect on the rate of growth and the individual bank size depends on the absolute values of the shift and the swing of the  $G_1$  and  $G_2$  curves, respectively.

**FIG. 2.** Swing of the  $G_2$  curve with a reduction in  $\hat{\pi}$

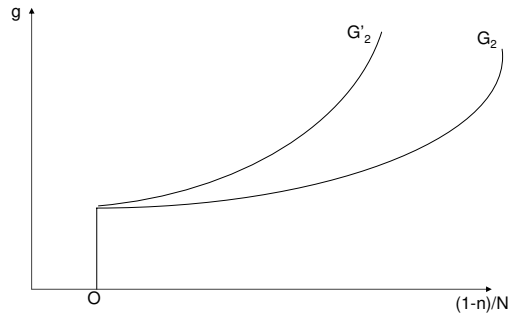

We will analyze the effects of the disinflationary policy at the stable equilibrium, i.e., we are assuming that the economy has reached the threshold level of financial sector development necessary to ensure the high-growth and high-welfare stable equilibrium A. The growth rate increases, remains same or decreases, at the stable equilibrium, following a reduction in  $\hat{\pi}$ , iff

$$\frac{\beta\gamma}{\sigma g^{(\sigma-1)}} \begin{matrix} \geq \\ \leq \end{matrix} A \frac{(1-\alpha)n^{-\alpha}(1-n)}{(A\alpha n^{(1-\alpha)} + (1-\delta_k))} \frac{1}{\epsilon} \quad (47)$$

The assertions made above have been depicted graphically in Figures 4, 5 and 6, respectively, resulting from the nature and size of movements of the  $G_1$  and  $G_2$  curves, with the standard assumption of  $\sigma > 1$ . Clearly, the resulting effect on the gross rate of growth is ambiguous, and depends crucially on the initial level of growth, the individual bank size, thus, the

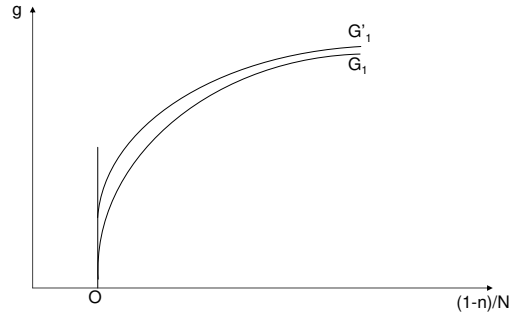
**FIG. 3.** Shift of the  $G_1$  curve with a reduction in  $\hat{\pi}$ 

level of financial sector development and the degree of competition, the degree of risk aversion and the elasticity of output with respect to capital or labor, besides the size of the discount factor and the reserve requirements. Note, a fall in  $\hat{\pi}$  will also result in ambiguous effect on the size of the individual bank. Though, Figures 4, 5 and 6 indicate the mixed effect on growth accompanied by a fall in  $\frac{1-n}{N}$  following disinflation, the possibility of an increase in growth rate along with an increase or unchanged individual bank size after disinflation cannot be ruled out. Figures 7 and 8 depict the scenarios, respectively.

Intuitively speaking, one could explain the ambiguous relationship between a disinflationary policy and growth as follows: All things equal, a fall in  $\hat{\pi}$  raises the real interest rate on the deposits and, hence, the growth rate via increases in the supply of deposit, and loans. Given that the nominal interest on loans has to fall to ensure that the real interest rate stays constant, the real wage rate must fall, given the equalization of the marginal product of labor to real wage rate, in the banking sector. A fall in the real wage rate, implying a fall in the marginal product of labor must be accompanied by a rise in the demand, and, hence, employment of labor in the output sector.<sup>7</sup> The movement of the labor force out of the banking

<sup>7</sup>Note a rise in  $n$  would increase the marginal product of capital and ensure that the real interest rate rises in the new steady-state, which, in turn, requires the nominal interest rate to increase after the initial decline. Hence, the ultimate decline in the



sector would tend to reduce the efficiency of the intermediation process and, in turn, affect the growth rate negatively. Further, a decline in the development of the banking sector, would also negatively affect the growth rate by increasing the intermediation cost through a fall in the competition effect, i.e., via the decline in  $N$ . Clearly then, the effects on both the growth rate and the individual bank size is ambiguous and depends on which of the two effects dominate.<sup>8</sup>

Several other interesting observations can be made from the figures 2 and 3, and the above relationship, defined by equation (47).

**FIG. 4.** Growth-enhancing effect of a lower inflation target

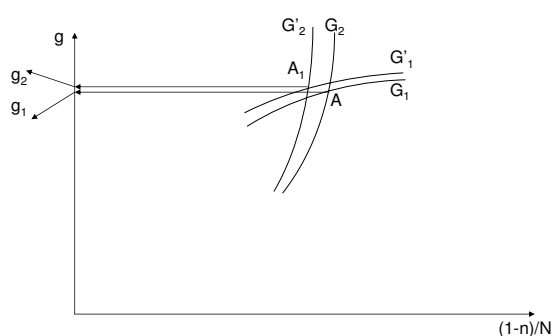

- Given the nature of movements of the two curves  $G_1$  and  $G_2$ , an economy is more likely to have a positive effect on growth following disinflation, at moderate levels of initial growth and financial sector development. This is because, at higher levels of individual bank size, the negative influence on growth resulting from financial development, via a fall in the productivity of capital, is likely to exceed the positive effect via an improvement in the efficiency of capital intermediation. This result is in line with wide empirical evidence regarding inflation targeting being more beneficial for

nominal interest rate should be less than proportional to the decline in the targeted inflation.

<sup>8</sup>However note, it is impossible to experience a fall in growth rate and an increase in the individual bank size following a reduction in the inflation target, once we realize the channels through which a disinflationary policy tends to affect growth.

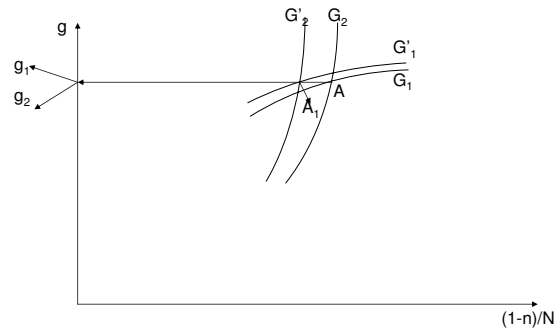
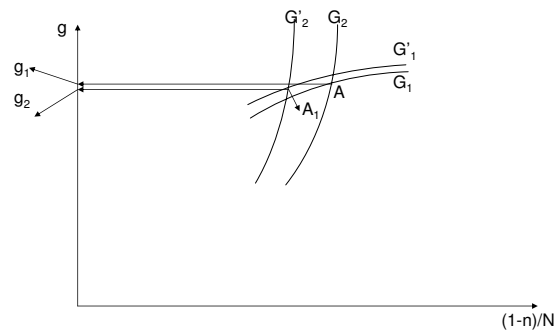
**FIG. 5.** Growth-neutral effect of a lower inflation target**FIG. 6.** Growth-reducing effect of a lower inflation target

developing rather than developed economies, since developed economies are likely to have more advanced and efficient financial systems;

FIG. 7. Growth-enhancing effect of a lower inflation target

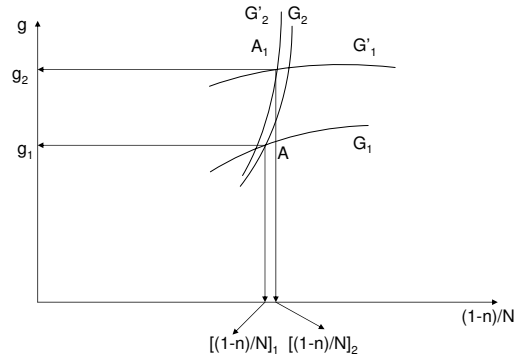
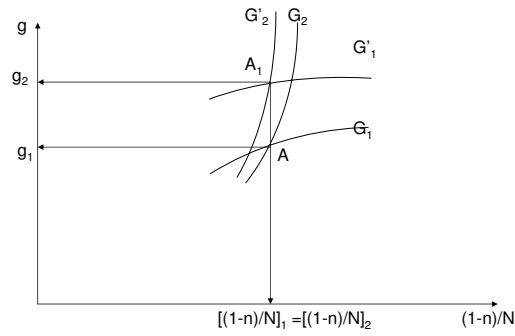

FIG. 8. Growth-enhancing effect of a lower inflation target



- Given the parameters,  $A$ ,  $\beta$ ,  $\gamma$ ,  $\alpha$ ,  $\delta_k$  and  $\sigma$ , the condition, given by equation (47), implies that a disinflationary policy is likely to be effective,

in enhancing growth rate, in an economy that achieves the same initial growth rate of another economy but with lower levels of financial sector development;

- Between two economies, the disinflationary policy will increase the rate of growth for the economy with comparatively lower levels of growth achieved for similar levels of financial sector development, given  $A$ ,  $\delta_k$ ,  $\beta$ ,  $\gamma$ ,  $\alpha$  and  $\sigma > 1$ . However, for lower degrees of risk aversion, specifically  $\sigma < 1$ , the result is reversed. Note, if the coefficient of relative risk aversion is unity, then the relationship is independent of the initial rate of growth;

- Given two economies with similar levels of growth rate corresponding to similar degrees of financial sector development, the economy with higher values of  $\beta$ ,  $\gamma$  and  $\alpha$  and lower values of  $\sigma$ ,  $A$  and  $\delta_k$ , will have positive growth effects of a disinflationary policy. Intuitively, this makes sense, because the higher the value of  $\beta$  the more one values the future and, hence, savings. Again, higher the value of the elasticity of output with respect to capital ( $\alpha$ ) and lower the depreciation rate, the more likely it is for the positive effects of a disinflationary policy to dominate the negative effect. Further, higher the value of  $\gamma$ , higher is the increase in the real deposit rate, and, hence, growth, following a fall in  $\hat{\pi}$ , while, given that,  $\frac{1}{\sigma}$  is the elasticity of deposits with respect to the interest rate, a lower value of the relative degree of risk aversion would ensure a positive effect on growth for a lower inflation target. Finally, higher the value of  $A$ , higher is the decline in the marginal product of capital following an increase in the financial sector development, and, hence, less likely it is for the deflationary policy to be growth enhancing.<sup>9</sup>

Importantly, our model is in line with recent empirical evidence regarding inflation targeting governments in developing economies pursuing a disinflationary policy is likely to be more effective than developed economies (Fang *et al.*, 2009, 2010; and Fang and Miller, 2010). This issue can also be numerically stressed by parametrizing the model, where most of the parameters have been obtained from Gupta and Uwilingiye (2010), and considering the condition outlined in equation (47). Setting  $\sigma = 2.0$ ,  $g = 1.03$ ,  $\beta = 0.96$ ,  $\gamma = 0.25$ ,  $\alpha = 0.24$ ,  $\delta = 0.076$ ,  $n = 0.62$ <sup>10</sup> and  $A = 0.39$ , would require the elasticity of the intermediation of deposits with respect

<sup>9</sup>Interestingly, the model tends to suggest that economies with no reserve requirements will always be negatively influenced in terms of growth after a disinflationary policy. However, if the initial level of financial sector development is large enough to cause the  $G_1$  curve to slope downwards, a tight monetary policy is growth enhancing. Given that nearly all, if not all economies, tend to have positive cash-reserve requirements, we do not want to place too much of an emphasis on these set of results.

<sup>10</sup>Note, unlike Gupta and Uwilingiye (2010), our model does not have leisure. Hence, the fraction of time devoted to leisure in the paper of Gupta and Uwilingiye (2010) was equally distributed amongst the production and banking sector activities in our parameterization.

to employment at the bank level, i.e.,  $\epsilon$  to be  $> 1.07$  for disinflationary policy to have a positive impact on growth. A value of  $\epsilon$  less than 1.07, would result in a negative influence of disinflation on growth. Recall,  $\epsilon$  is negatively related to the level of financial sector development, hence, for developed economies, this value is likely to be lesser than developing economies. Or in other words, once the threshold level of financial sector development has been achieved, disinflationary policy can only have a positive impact on growth for modest levels of financial sector development. In terms of the figures, the further down we move along the  $\frac{1-n}{N}$  axis, i.e., more developed the financial sector becomes, the lower is the value of  $\epsilon$ , with the shift of the  $G_1$  curve becoming smaller and the swing of the  $G_2$  curve becoming bigger, causing disinflationary policy to be less likely in enhancing growth, since the right-hand side of equation (47) is likely to dominate the left-hand side of the same.

## 5. CONCLUSIONS

Empirical evidences on the growth effects of inflation targeting, is at best, varied, with disinflationary policies observed to have significant and insignificant positive and negative effects, respectively. This paper tries to provide a theoretical justification to such ambiguity observed in the data. Moreover, with developing and emerging market economies also adapting the inflation targeting framework, a pertinent question is what are the essential prerequisites for inflation targeting to have positive and stable growth effects in these countries. The paper also addresses the above issue by emphasizing the importance of financial sector development. In this regard, we develop a dynamic general equilibrium monetary endogenous growth model of a closed economy inhabited by consumers, firms, a Cournotian monopolistically competitive banking system, besides, an inflation-targeting monetary authority, and, in turn, analyze the effect of a tight monetary (disinflationary) policy on growth.

Our analysis indicates the possibility of multiple equilibria, and emphasizes that unless a threshold level of financial sector development is achieved, the high-growth and high-welfare (stable) equilibrium available to the economy cannot be attained. However, the effect of a lower inflation target on growth is shown to be ambiguous, with the ultimate effect depending critically on the initial level of growth, the individual bank size, thus, the level of financial sector development and the degree of competition, the degree of risk aversion and the elasticity of output with respect to capital or labor, besides, the size of the discount factor, the depreciation rate, the production scalar and the reserve requirements. In summary, results tend to suggest that, once the threshold level of financial sector has been achieved, a tight monetary policy is likely to be growth-enhancing at

moderate levels of financial sector development and growth. At high initial levels of growth and financial sector development, however, a lower inflation target is more likely to increase growth for economies with relatively lesser risk averse agents. Thus, from a policy perspective, this model indicates that pursuing lower inflation targets cannot always guarantee higher growth rate, since, the results would depend critically on the structural parameters of the economy.

An immediate extension of the current analysis would be to calibrate the existing model to real economies that target inflation, and derive country-specific values for the threshold level of financial sector development. This, in turn, would help drawing better policy conclusions for the particular economy under consideration. Moreover, the calibrated model would also help in numerically analyzing the effects of a disinflationary policy on the other endogenous variables of the model, from which some other interesting results might be obtained. Finally, one could also think of endogenizing the growth process by allowing for productive public expenditure, along the lines of Barro (1990), and redoing the policy experiment of disinflation.

## REFERENCES

- Apergis, N., S. M. Miller, A. Panethimitakis, and A. Vamvakidis, 2005. Inflation targeting and output growth: evidence from aggregate European data. *University of Connecticut Working Paper Series 2005-06*, University of Connecticut.
- Ball, L. and N. Sheridan, 2003. Does inflation targeting matter? *IMF Working Paper Series 03/129*, International Monetary Fund.
- Barro, R. J., 1990. Government spending in a simple model of endogenous growth. *Journal of Political Economy* **98(5, Part - 2)**, S103-S125.
- Bencivenga, V. R. and B. D. Smith, 1991. Financial intermediation and endogenous growth. *Review of Economic Studies* **58(2)**, 195-209.
- Berthélemy, J. C. and A. Varoudakis, 1997. Financial development, policy and economic growth, in: R. Lensink & and N. Hermes (Eds) *Financial Development and Growth: Theory and Experiences from Developing Countries* (London: Routledge Publications).
- Chari, V. V., R. E. Manuelli, and L. E. Jones, 1995. The growth effects of monetary policy. *Federal Reserve Bank of Minneapolis Quarterly Review* **19(4)**, 18-32.
- Dutt, A. and J. Ros, 2003. Contractionary effect of stabilization and long-run growth. *Unpublished Manuscript*, University of Norte Dame.
- Espinosa, M. and C. K. Yip, 1996. An endogenous growth model of money, banking, and financial repression. *Working Paper Series 96-04*, Federal Reserve Bank of Atlanta.
- Espinosa, M. and C. K. Yip, 1999. Fiscal and monetary policy interactions in an endogenous growth model with financial intermediaries. *International Economic Review* **40(3)**, 595-613.
- Fang, W-S., C-S. Lee, and S. M. Miller, 2009. Inflation targeting evaluation: short-run costs and long-run irrelevance. *Working Paper Series 2009-14*, University of Connecticut, Department of Economics.

- Fang, W-S. and S. M. Miller, 2010. The lag effect of inflation targeting and policy evaluation. *Working Paper Series 2010-01*, University of Connecticut, Department of Economics.
- Fang, W-S., C-S. Lee, and S. M. Miller, 2010. What can we learn about inflation targeting? Evidence from time-varying treatment. *SSRN Working Paper Series*.
- Fraga, A., A. Goldfajn, and A. Minella, 2003. Inflation targeting in emerging market economies, *NBER Working Paper Series 10019*. National Bureau of Economic Research.
- Gupta, R. and J. Uwilingiye, 2010. Evaluating the welfare cost of inflation in a monetary endogenous growth general equilibrium model: The case of South Africa. *International Business and Economics Research Journal* **9(8)**, 101-112.
- Lavoie, M., 2002. A post Keynesian alternative to the new consensus on monetary policy. ADEK Conference, November, France.
- Libanio, G. A., 2005. "Good governance" in monetary policy and negative real effects of inflation targeting in real economies. *CEDEPLAR Discussion Paper Series 277*, Federal University of Minas Gerais.
- Miguel, L. and A. P. Thirlwall, 2002. The endogeneity of the natural rate of growth. *Cambridge Journal of Economics* **26(4)**, 441-459.
- Mishkin, F., 2001. From monetary targeting to inflation targeting: lessons from industrialized countries. *Policy Research working Paper 2684*, World Bank.
- Mishkin, F., 2004. Can inflation targeting work in emerging market countries? *NBER Working Paper Series 10646*, National Bureau of Economic Research.
- Mollick, A. V., R. C. Torres, and F. G. Carneiro, 2008. Does inflation targeting matter for output growth? Evidence from industrial and emerging economies. *World Bank Policy Research Paper 4971*, The World Bank.
- Neumann, M. and J. von Hagen, 2002. Does inflation targeting matter? *Federal Reserve Bank of St. Louis Review* **84(4)** 127-146.
- Romer, P., 1986. Increasing returns and long-run growth. *Journal of Political Economy* **94(5)**, 1002-1037.
- Vega, M. and D. Winkelried, 2005. Inflation targeting and inflation behavior: A successful story? *International Journal of Central Banking* **1(3)**, 153-175.